

MARSHALL AVENUE CONCRETE SIDEWALK IMPROVEMENTS

PERKINS TOWNSHIP

ERIE COUNTY, OHIO

LEGEND		
EXISTING	PROPOSED	DESCRIPTION
--- SA ---	--- SA ---	SANITARY SEWER
--- ST ---	--- ST ---	STORM SEWER
--- W ---	--- W ---	WATER MAIN
--- G ---	--- G ---	GAS LINE
--- T ---	--- T ---	TELEPHONE LINE
--- OE ---	--- OE ---	OVERHEAD ELECTRIC LINE
--- E ---	--- E ---	ELECTRIC LINE
--- CATV ---	--- CATV ---	CABLE & TELEVISION LINE
--- X X X X ---	--- X X X X ---	FENCE LINE
--- C ---	--- C ---	CENTER LINE
--- + ---	--- 1+ 2+ ---	BASE LINE
		RIGHT OF WAY LINE
○	●	MANHOLE
□	■	CATCH BASIN
○	○	CLEANOUT
○	○	WATER MAIN VALVE & BOX
○	○	FIRE HYDRANT
○	○	WATER METER
○	○	GAS METER
○	○	WATER VALVE
○	○	GAS VALVE
○	○	POWER POLE
○	○	LIGHT POLE
○	○	POLE W/ DOWN GUY
○	○	TREE
○	○	HEDGE
○	○	SIGN

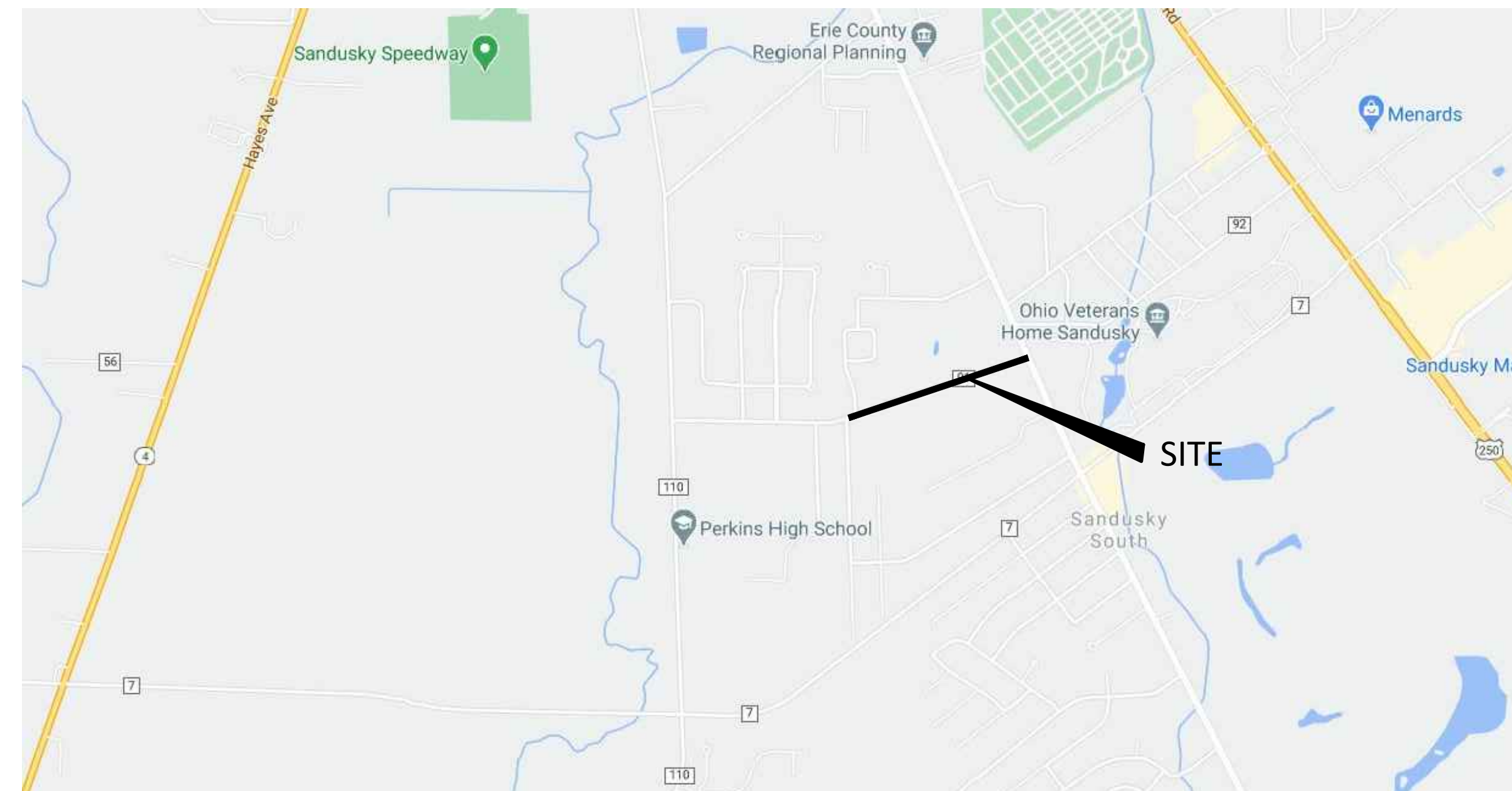

SITE MAP

GENERAL NOTES			
SPECIFICATIONS: The current Construction and Material Specifications (CMS) of the State of Ohio Department of Transportation, including any changes and supplemental specifications listed hereon, shall govern this project.			
Item numbers referred to herein conform to the State of Ohio, Department of Transportation, Construction and Material Specifications, Current Edition.			
ELEVATION DATUM All elevations are based on NAVD '88 (2011) Datum and verified by a Surveyor.			
PERMITS The contractor shall be responsible for obtaining all necessary permits.			
UNDERGROUND UTILITIES The locations of the underground utilities shown on the plans have been obtained by diligent field checks and searches of available records. It is believed that they are essentially correct, but Contractors Design Engineering, nor Perkins Township guarantee their accuracy or completeness. The exact location and projection of the underground utilities are the responsibility of the contractor.			
OHIO UTILITY PROTECTION SERVICE: The contractor shall notify the Ohio Utility Protection Service [800-362-2764] forty-eight [48] hours before his work is in progress and shall make such arrangements as are necessary in the event emergency repairs should become necessary.			
LIST OF UTILITIES			
Gas	Columbia Gas of Ohio, Inc. 1800 Broad Ave. Findlay, Ohio 45840 Phone: 419-427-3227	Sanitary Sewers & Water Mains	Erie County Department of Environmental Services 554 River Road Huron, Ohio 44839 Phone: 419-433-7303
Telephone	A T & T 130 N. Erie Street, RM 206 Toledo, Ohio 43604 Phone: 419-245-7491	Electric	Ohio Edison Company 2508 W. Perkins Ave. Sandusky, Ohio 44870 Phone: 419-627-6889
Cable T.V.	Buckeye Broadband 2700 Oregon Road Northwood, Ohio 43619	Street & Storm	Perkins Township Highway Dept. 2610 Columbus Ave. Sandusky, Ohio 44870 Phone: 419-609-1400
EXISTING ROADWAY DRAINAGE Existing roadway ditches, culverts pipes and drives disturbed during construction shall be regraded and replaced to conform to conditions prior to construction and shall be seeded as directed by the Engineer or the Township.			
LAWN AREAS: Existing lawn areas disturbed during construction shall be replaced to a condition equal to or exceeding original condition and as approved by the Engineer or the Township.			
EXISTING TREES Existing trees not indicated for removal shall not be disturbed during construction operations. All cuts or wounds measuring one or more inches in diameter and all exposed wood or scars resulting from this construction shall be painted with an approved paint or tree wound dressing.			
ITEM 614, MAINTAINING TRAFFIC Traffic shall be maintained on all roads of this project at all times. Length and duration of the lane closures and restrictions shall be at the approval of Perkins Township. It is the intent to minimize the impact to the traveling Public. The Contractor shall provide, erect and maintain signs, barricades, gates and lights in accordance with ODOT 614 and other applicable portions of the specifications, as well as the Ohio Manual of Uniform Traffic Control Devices. Payment for all labor, equipment and materials shall be included in the Lump Sum price for Item 614 Maintain Traffic, unless separately itemized in the Plan.			
UTILITY SERVICES Relocation or repair of utility services, disturbed by the work will be the responsibility of the contractor. The cost shall be included in the cost of the project.			
UTILITY POLES All utility poles within this project that require relocation shall be moved by their respective owners so not as to interfere with the progress of the work. The contractor shall coordinate with the respective utility owners to provide adequate temporary support when trenching near the remaining utility poles and guy wires.			
CONSTRUCTION LAYOUT All construction layout shall be the responsibility of the contractor and shall be provided by a Licensed Professional Surveyor.			

PROJECT DESCRIPTION
This project will include the construction and stabilization of sidewalk as well as asphalt planing and replacement on Marshall Ave. (between Matthes Ave. & Columbus Ave.).

BENCHMARKS
BENCHMARK #1 1" iron rod in monument box at centerline intersection of Marshall Ave. & Stony Ridge Dr. Sta. 1+30.69 Elevation: 605.30 NAVD '88
BENCHMARK #2 1" iron rod in monument box on centerline of Marshall Ave. Sta. 7+83.21 Elevation: 598.37 NAVD '88
BENCHMARK #3 1" iron rod in monument box at centerline intersection of Marshall Ave. & Columbus Ave. Sta. 20+41.50 Elevation: 601.72 NAVD '88

INDEX	
NO.	DESCRIPTION
1	TITLE SHEET
2	GENERAL NOTES & DETAILS
3	MARSHALL AVE. - STA. 0+00 TO 12+00
4	MARSHALL AVE. - STA. 12+00 TO 20+75

UNDERGROUND UTILITIES

TWO WORKING DAYS
BEFORE YOU DIG
CALL 1-800-362-2764 (TOLL FREE)
OHIO UTILITIES PROTECTION SERVICE
NON-MEMBERS
MUST BE CALLED DIRECTLY

PLANS PREPARED BY

Engineer & Surveyor
Contractors Design Engineering, Ltd.
1623 Old State Road
Norwalk, Ohio 44857
Phone: (419) 663-0885
Fax: (419) 663-2805
E-Mail: alex@contractorsdesigneng.com

Alexander B. Etchill
Alexander B. Etchill, P.E., P.S.

the 14th day of January, 2021

MARSHALL AVE.
CONCRETE IMPROVEMENTS

TITLE SHEET

1
4

**CONTRACTORS
DESIGN ENGINEERING**
CONSULTING ENGINEERS & SURVEYORS
NORWALK, OHIO

DATE: JANUARY, 2021
DR: BLH
BY:

BY: ABE
REV'D BY:

PROJECT NO.
19-350



File Name: \\NASRIVEN\Drawz\CDD\19-350-Marshall Ave. Sidewalk - Perkins Township\19-350 Revised Jan. 2021.dwg

GENERAL NOTES

- UTILITY COMPANIES SHALL BE NOTIFIED PRIOR TO THE START OF CONSTRUCTION SO THAT EACH CAN LOCATE AND/OR PROTECT THEIR UTILITIES.
- WORK UNDER THIS CONTRACT SHALL BE LIMITED TO PUBLIC RIGHT-OF-WAY AND EASEMENTS OBTAINED BY THE OWNER AS SHOWN ON THE DRAWINGS. ANY ADDITIONAL CONSTRUCTION EASEMENTS REQUIRED FOR COMPLETION OF WORK UNDER THIS CONTRACT SHALL BE OBTAINED BY THE CONTRACTOR.
- GAS AND SOME WATER SERVICE LINES ARE NOT SHOWN ON THE DRAWINGS, CONTRACTOR SHOULD ASSUME A GAS AND WATER SERVICE FOR EVERY EXISTING STRUCTURE. SERVICE LINES WILL BE LOCATED BY THE UTILITY OWNER AT THE TIME OF CONSTRUCTION.
- THE CONTRACTOR SHALL PERFORM THE WORK IN SUCH MANNER AS TO NOT REQUIRE CLOSING ANY STREET, ROAD PARKING LOT OR HIGHWAY TO TRAFFIC AT ANY TIME WITHOUT PRIOR WRITTEN PERMISSION TO DO SO FROM THE OWNER. ALL SIGNS DETOURING AND BARRICADING MUST BE PRE-APPROVED BY THE OWNER AND SHALL BE IN ACCORDANCE WITH THE 'OHIO MANUAL OF UNIFORM TRAFFIC CONTROL DEVICES FOR STREETS AND HIGHWAYS'.
- WHERE IT IS NECESSARY TO DISTURB SIGNS, LAWNS, DRIVEWAYS, LANDSCAPING, FENCES, SHRUBS, MAILBOXES, ETC. IT SHALL BE THE CONTRACTOR'S RESPONSIBILITY TO RESTORE THE AREA TO A CONDITION AT LEAST AS GOOD AS IT WAS PRIOR TO THE ONSET OF CONSTRUCTION.
- WHEREVER IN THE CONTRACT DOCUMENTS REFERENCE IS MADE TO THE CONSTRUCTION AND MATERIALS SPECIFICATIONS OF THE OHIO DEPARTMENT OF TRANSPORTATION (ODOT) CURRENT EDITION, THE PROVISIONS OF THE REFERENCED ITEM SHALL HAVE THE FULL FORCE AND EFFECT AS IF REPRODUCED HEREIN IN THEIR ENTIRETY. HOWEVER, THE METHOD OF MEASUREMENTS, BASIS OF PAYMENT AND PAY ITEMS SHALL BE AS DIRECTED IN THE MATERIAL SPECIFICATIONS OR BID PROPOSAL FORMS. THE CONTRACTOR SHALL BE RESPONSIBLE FOR PROVIDING HIS OWN COPY OF THE ODOT CONSTRUCTION AND MATERIAL SPECIFICATIONS.
- ALL PROPERTY PINS OR MONUMENTS WHICH ARE REMOVED OR DISTURBED DURING CONSTRUCTION SHALL BE REPLACED IN THE SAME LOCATION THEY OCCUPIED PRIOR TO CONSTRUCTION. THIS WORK SHALL BE COMPLETED BY A PROFESSIONAL SURVEYOR REGISTERED IN THE STATE OF OHIO.
- THE CONTRACTOR SHALL BE RESPONSIBLE FOR CONTROLLING DUST, DIRT AND MUD DUE TO CONSTRUCTION IN THE PROJECT AREA DURING THE LIFE OF THE PROJECT. DUST CONTROL OPERATIONS SHALL BE PERFORMED BY THE CONTRACTOR AT THE TIME, LOCATION AND IN THE AMOUNT ORDERED BY THE OWNER AND SHALL BE IN ACCORDANCE WITH ITEM 616 OF THE OHIO DEPARTMENT OF TRANSPORTATION CONSTRUCTION AND MATERIAL SPECIFICATIONS. THE COST FOR THESE OPERATIONS SHALL BE CONSIDERED AS GENERAL OVERHEAD COSTS AND NO SEPARATE COMPENSATION WILL BE MADE.
- THE CONTRACTOR SHALL BE RESPONSIBLE FOR TEMPORARY WATER POLLUTION, SOIL EROSION AND SILTATION CONTROL DUE TO CONSTRUCTION WITHIN THE PROJECT AREA AND DURING THE LIFE OF THE PROJECT. THESE TEMPORARY OPERATIONS SHALL BE PERFORMED IN ACCORDANCE WITH ODOT #207, LATEST REVISION AND AS DIRECTED BY THE ENGINEER. COST FOR SAID CONTROLS SHALL BE CONSIDERED AS GENERAL OVERHEAD COSTS AND NO SEPARATE COMPENSATION WILL BE MADE.
- NOT ALL GAS LINES AND FIBER OPTICS LINES MAY HAVE BEEN MARKED IN RESPONSE TO THE O.U.P.S. CALL. THE GAS LINES SHOWN ARE BASED ON A COMBINATION OF FIELD LOCATION AND MAPS PROVIDED BY COLUMBIA GAS AND ARE SHOWN IN THEIR APPROXIMATE LOCATION.

DETECTABLE WARNING NOTES

GENERAL: Detectable Warnings are a distinctive surface pattern of truncated domes which are detectable by cane or underfoot to alert people with vision impairments of their approach to streets and hazardous drop-offs.

PLACEMENT: Detectable warnings are to be installed at any location where pedestrians might cross paths with vehicular traffic lanes, such as the base of curb ramps or at blended curbs. A 24" strip of domes is to be installed for the full width of the ramp or walk. Typical street corner placement locations are shown on Sheet 1.

The depth of concrete underneath detectable warning products shall be a minimum of 4". See DETAIL A.

ALIGNMENT: Truncated domes should be aligned with the primary direction of the ramp as shown on the DETECTABLE WARNING ALIGNMENT DETAIL. Normally the detectable warnings should be flush with the back of the curb, but for skewed conditions see DETECTABLE WARNING ALIGNMENT DETAIL. For non-standard layouts, detectable warning materials may have to be mitered and placed segmentally.

PRODUCTS & COLORS: Color of the detectable warnings should contrast with surrounding concrete walk and ramp. Black is not an acceptable color. Approved products and guidance on color may be found on the Office of Roadway Engineering Service's Detectable Warnings Approved List. Install products as per manufacturer's printed instructions.

TRUNCATED DOMES DETAIL

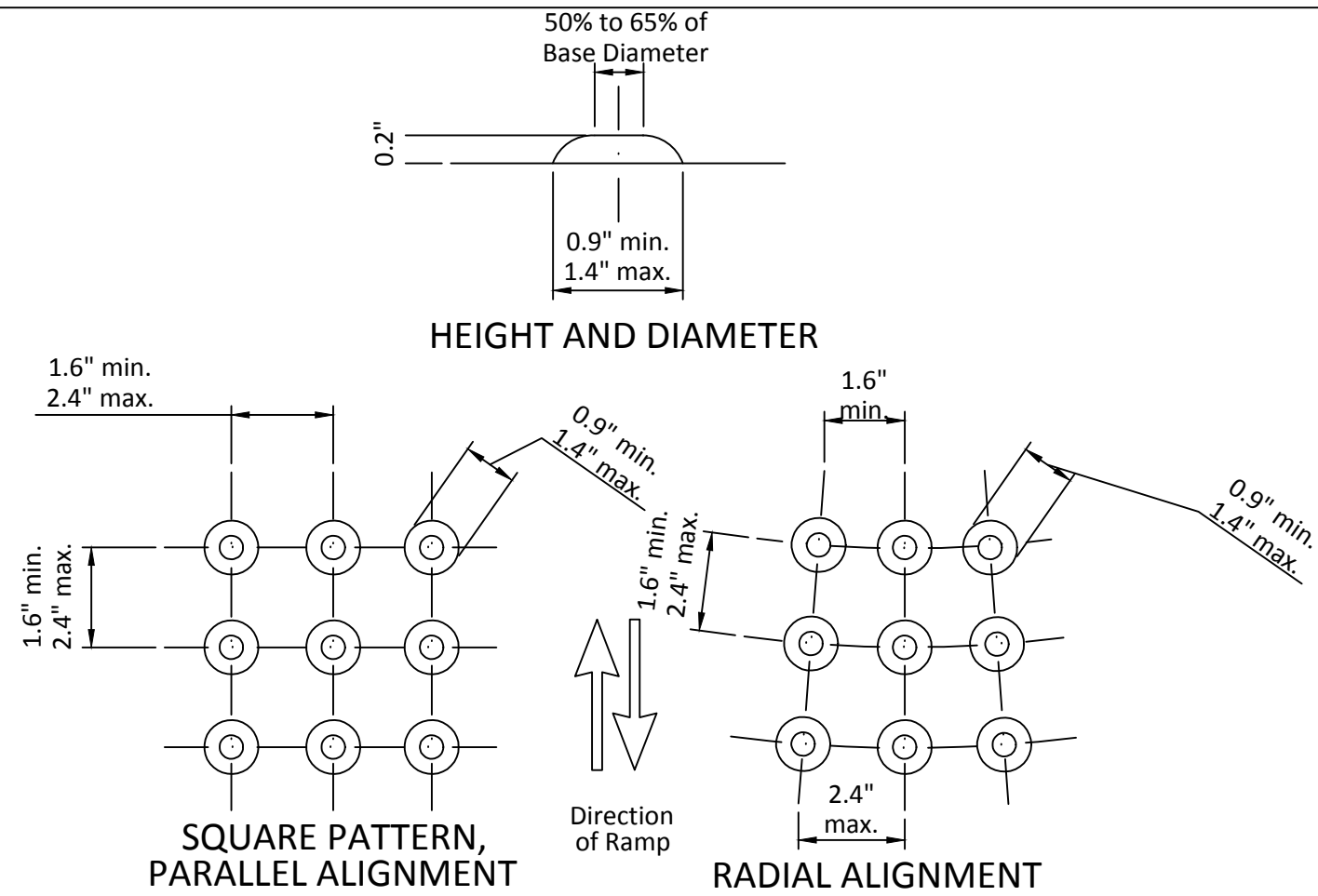

ODOT TYPE 6 CURB

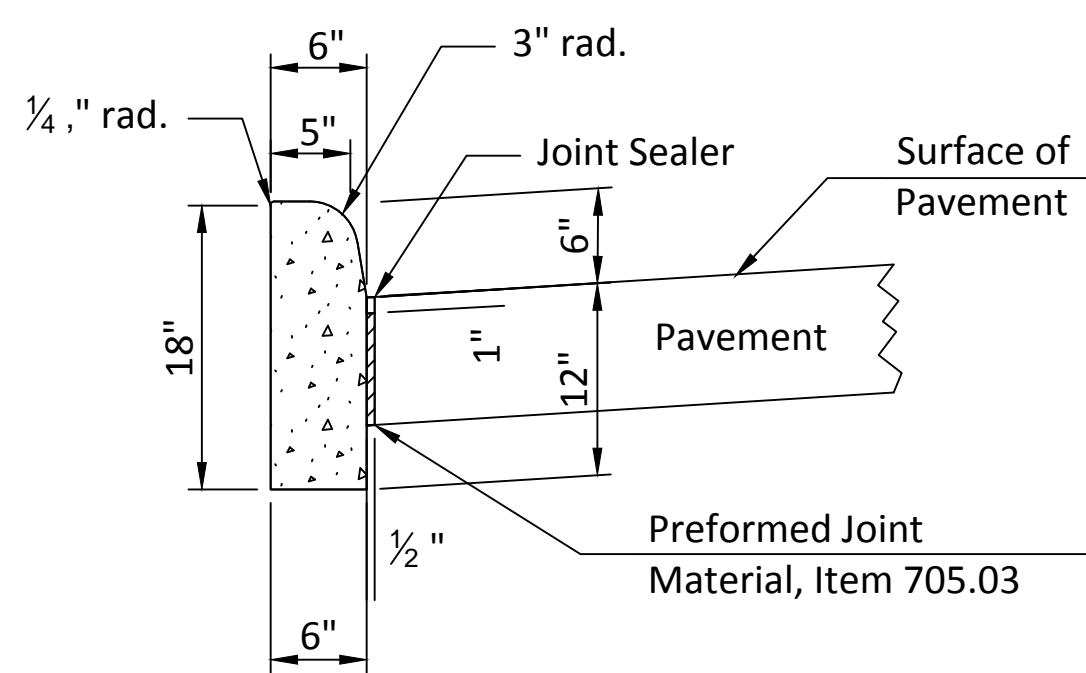

CONCRETE DRIVEWAY REPLACEMENT

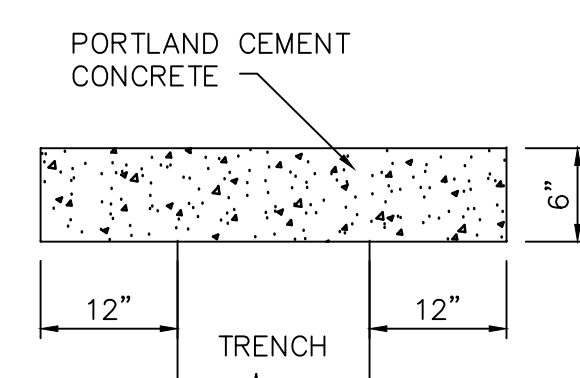

A. Pavement. The plain Portland cement concrete pavement shall be in accordance with ODOT Item 452.

PROPOSED SIDEWALK

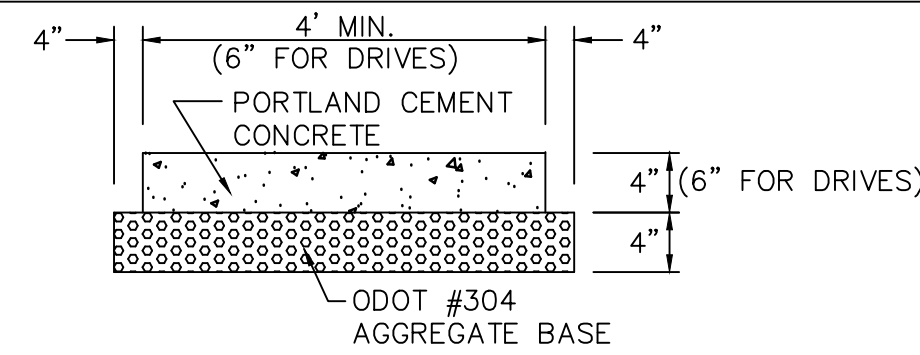

SIDEWALK

A. The Portland cement concrete walk with ODOT Item 304 aggregate base shall be in accordance with ODOT Item 608.

CURB RAMP DETAILS

NOTES

GENERAL: This drawing shows curb ramp types details and placement examples for curb ramp construction, including the installation of detectable warnings.

Curb ramp types are shown on Sheet 2 and include Perpendicular, Parallel, and Combined types as specified to be constructed in the locations shown on the project plans.

Curb ramps added to an existing intersection or walk should be individually detailed on the project plans to assure that the design is appropriate for site constraints and all items can be constructed to ADA standards. The contractor may adjust the placement of curb ramps if existing field conditions warrant with the approval of the Engineer.

PAYMENT: Measure and pay for the ramp area within the shaded limits of this drawing as Item 608 Curb Ramp, Square Foot. This includes the cost of any curb or gutter and gutter, detectable warnings, landing areas and any additional materials, installation, grading, forming, and finishing required within the shaded area.

Work beyond the shaded ramp/landing area is paid for as curb (609) and walk (608). Removal of existing curb, walk (or existing curb ramps) are paid under Item 202.

For at-grade crossing locations where only detectable warnings are required in order to achieve ADA compliance, measure and pay for the strip of detectable warnings as Item 608 Detectable Warning, Square Foot. The work to cast the ties in place will also require removal of existing pavement (Item 202) to the nearest joint, or if no joint exists, a minimum of 4 feet.

The running slope of the ramp is preferred to be 12:1 or flatter. In existing sidewalks, where the maximum ramp slope is not feasible due to site constraints (e.g. utility poles or vaults, right-of-way limits) it may be reduced as follows:

- 10:1 for a max. rise of 6",
- 8:1 for a max. rise of 3",
- 6:1 over a max. run of 2'-0" pref. slope is not feasible.

To prevent chasing the grade indefinitely, the transition from existing sidewalk to the shaded curb ramp area is not required to exceed 15 feet in length.

While ramps may be skewed to the crosswalk, the entire lower landing area must fall within the cross walk that the ramp serves and cannot be located in the traveled lane of opposing traffic.

The counter slope of the gutter or street at the foot of a curb ramp, landing, or blended transitions shall be 20:1 or flatter.

The bottom edge of the ramp shall change planes perpendicular to the landing.

The edge of the curb shall be flush with the edge of the adjacent pavement and gutter and surface slopes that meet grade breaks shall also be flush.

Ramp landings shall be 4' min. x 4' min. with a 50:1 or flatter cross slope and running slope.

DETECTABLE WARNINGS: Install Detectable Warnings on each curb ramp with approved materials, as shown on Sheet 3. Install these proprietary products as per manufacturer's written instructions.

DRAINAGE: Contractor is to ensure the base of each constructed curb ramp allows for proper drainage, without exceeding allowable cross slope or ramp slopes. Vertical change in level exceeding 3/8" between the 1) pavement and gutter, and 2) gutter and ramp, are not allowed.

SURFACE TEXTURE: Texture concrete surfaces by coarse brooming transverse to the ramp slopes to be rougher than the adjacent walk.

JOINTS: Provide expansion joints in the curb ramp as extensions of walk joints and consistent with Item 608.03 requirements for a new concrete walk. Provide a 1/2" Item 705.03 expansion joint filler around the edge of ramps built in existing concrete walks. Lines shown on this drawing indicate the ramp edges and slope changes, and do not necessarily indicate joint lines.

PARALLEL CURB RAMP DETAILS

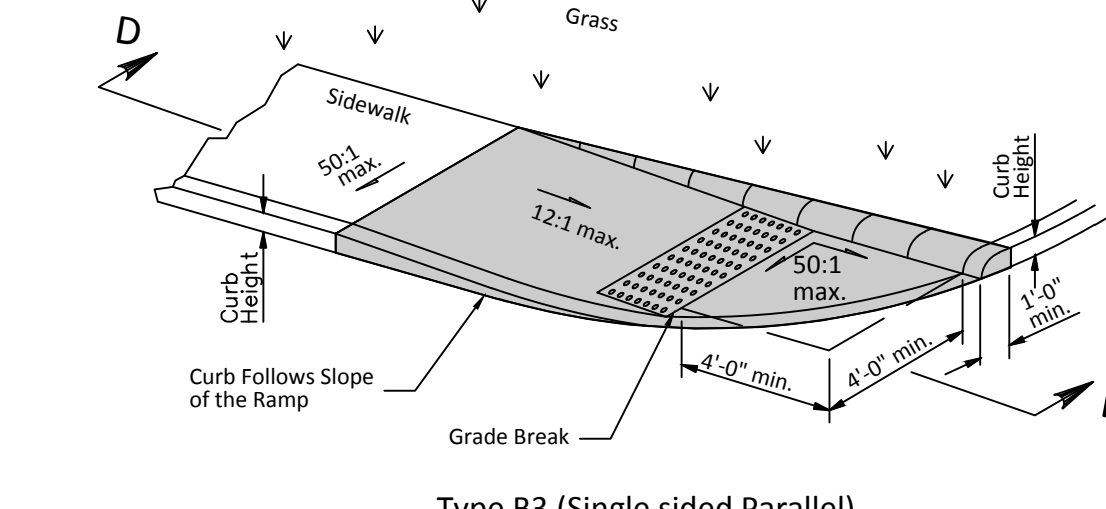
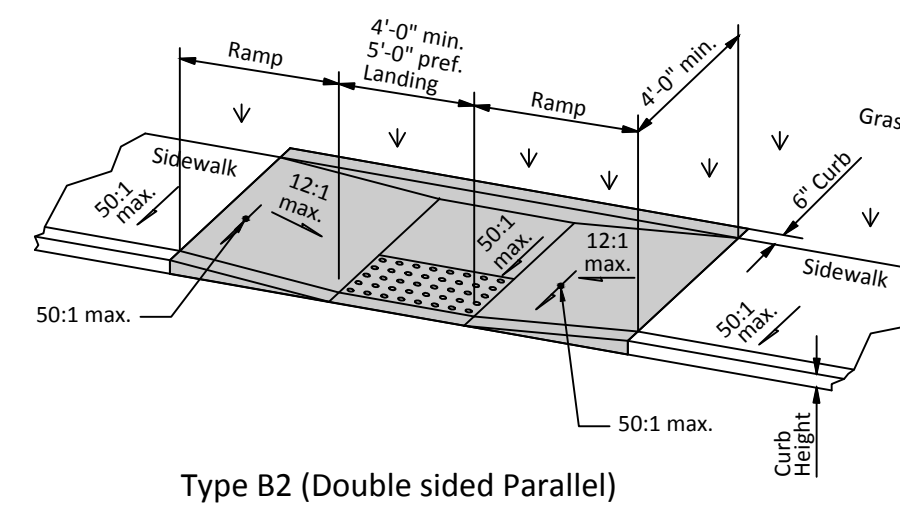
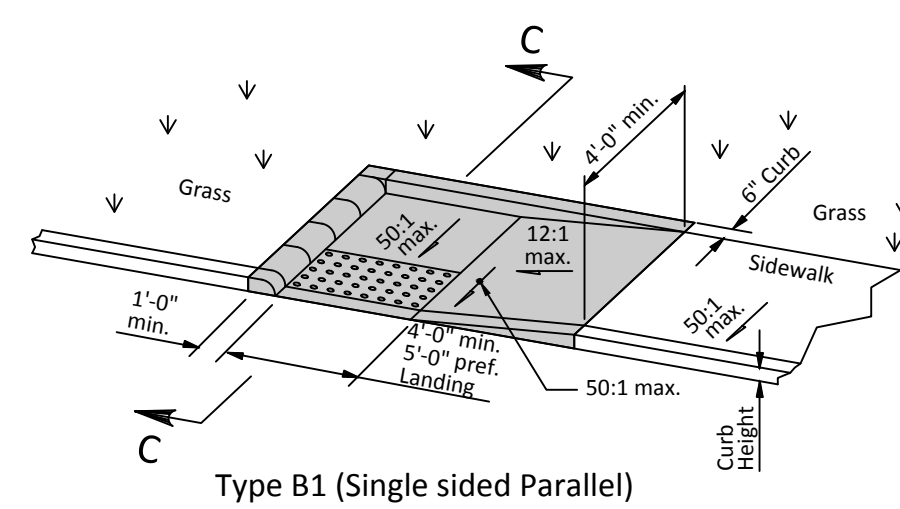

SPECIFICATIONS FOR PERMANENT SEEDING

Site Preparation

- Subsoil, plow, or other implement shall be used to reduce soil compaction and allow maximum infiltration. (Maximizing infiltration will help control both runoff rate and water quality.) Subsoiling should be done when the soil moisture is low enough to allow the soil to crack or fracture. Subsoiling shall not be done on slip-prone areas where soil preparation should be limited to what is necessary for establishing vegetation.
- The site shall be graded as needed to permit the use of conventional equipment for seedbed preparation and seeding.
- Topsoil shall be applied where needed to establish vegetation.

Seedbed Preparation

- Lime—Agricultural ground limestone shall be applied to acid soil as recommended by a soil test. In lieu of a soil test, lime shall be applied at the rate of 100 pounds per 1,000-sq. ft. or 2 tons per acre.
- Fertilizer—Fertilizer shall be applied as recommended by a soil test. In place of a soil test, fertilizer shall be applied at a rate of 25 pounds per 1,000-sq. ft. or 1000 pounds per acre of a 10-10-10 or 12-12-12 analyses.
- The lime and fertilizer shall be worked into the soil with a disk harrow, spring-tooth harrow, or other suitable field implement to a depth of 3 inches. On sloping land, the soil shall be worked on the contour.

Seeding Dates and Soil Conditions

Seeding should be done March 1 to May 31 or August 1 to September 30. If seeding occurs outside of the above-specified dates, additional mulch and irrigation may be required to ensure a minimum of 80% germination. Tillage for seedbed preparation should be done when the soil is dry enough to crumble and not form ribbons when compressed by hand. For winter seeding, see the following section on dormant seeding.

Dormant Seedings

- Seedings should not be made from October 1 through November 20. During this period, the seeds are likely to germinate but probably will not be able to survive the winter.
- The following methods may be used for "Dormant Seeding":
 - From October 1 through November 20, prepare the seedbed, add the required amounts of lime and fertilizer, then mulch and anchor. After November 20, and before March 15, broadcast the selected seed mixture. Increase the seeding rates by 50% for this type of seeding.
 - From November 20 through March 15, when soil conditions permit, prepare the seedbed, lime and fertilize, apply the selected seed mixture, mulch and anchor. Increase the seeding rates by 50% for this type of seeding.

- Apply seed uniformly with a cyclone seeder, drill, cultipacker seeder, or hydro-seeder (slurry may include seed and fertilizer) on a firm, moist seedbed.
- Where feasible, except when a cultipacker type seeder is used, the seedbed should be firm following seeding operations with a cultipacker, roller, or light drag. On sloping land, seeding operations should be on the contour where feasible.

Mulching

- Mulch material shall be applied immediately after seeding. Dormant seeding shall be mulched. 100% of the ground surface shall be covered with an approved material.
- Materials
 - Straw—If straw is used it shall be unrotted small-grain straw applied at the rate of 2 tons per acre or 90 pounds (two to three bales) per 1,000-sq. ft. The mulch shall be spread uniformly by hand or mechanically applied so the soil surface is covered. For uniform distribution of hand-spread mulch, divide area into approximately 1,000-sq.-ft. sections and spread two 45-lb. bales of straw in each section.
 - Hydroseeders—If wood cellulose fiber is used, it shall be applied at 2,000 lb./ac. or 46 lb./1,000 sq. ft.
 - Other—Other acceptable mulches include rolled erosion control matings or blankets applied according to manufacturer's recommendations or wood chips applied at 6 tons per acre.
- Straw and Mulch Anchoring Methods
 - Straw mulch shall be anchored immediately to minimize loss by wind or water.
 - Mechanical—A disk, crimper, or similar type tool shall be set straight to punch or anchor the mulch material into the soil. Straw mechanically anchored shall not be finely chopped but, generally, be left longer than 6 inches.
 - Mulch Netting—Netting shall be used according to the manufacturer's recommendations. Netting may be necessary to hold mulch in place in areas of concentrated runoff and on critical slopes.
 - Asphalt Emulsion—Asphalt shall be applied as recommended by the manufacturer or at the rate of 160 gallons per acre.
 - Synthetic Binders—Synthetic binders such as Acrylic DLR (Agri-Tac), DCA-70, Petrosel, Terra Tack or equivalent may be used at rates specified by the manufacturer.
 - Wood Cellulose Fiber—Wood cellulose fiber shall be applied at a net dry weight of 750 pounds per acre. The wood cellulose fiber shall be mixed with water with the mixture containing a maximum of 50 pounds cellulose per 100 gal- lons of water.

Irrigation

Permanent seeding shall include irrigation to establish vegetation during dry weather or on adverse site conditions, which require adequate moisture for seed germination and plant growth.

Irrigation rates shall be monitored to prevent erosion and damage to seeded areas from excessive runoff.

TRAFFIC CONTROL

During Construction the CONTRACTOR to maintain one lane of traffic at all times within the block where Construction is taking place by means of temporary signals and/or flagmen.

At the end of everyday and non-working days the CONTRACTOR will maintain two-way traffic within the Construction areas by moving his equipment off site and/or locating it in such a way that two-way traffic can be maintained in an orderly safe manner by means of a "safety zone", approved by the TOWNSHIP around his equipment.

The cost of the above TRAFFIC CONTROL measures shall be included in the Cost for "Maintaining Traffic".

DOMES ALIGNMENT ON RADIUS CURB

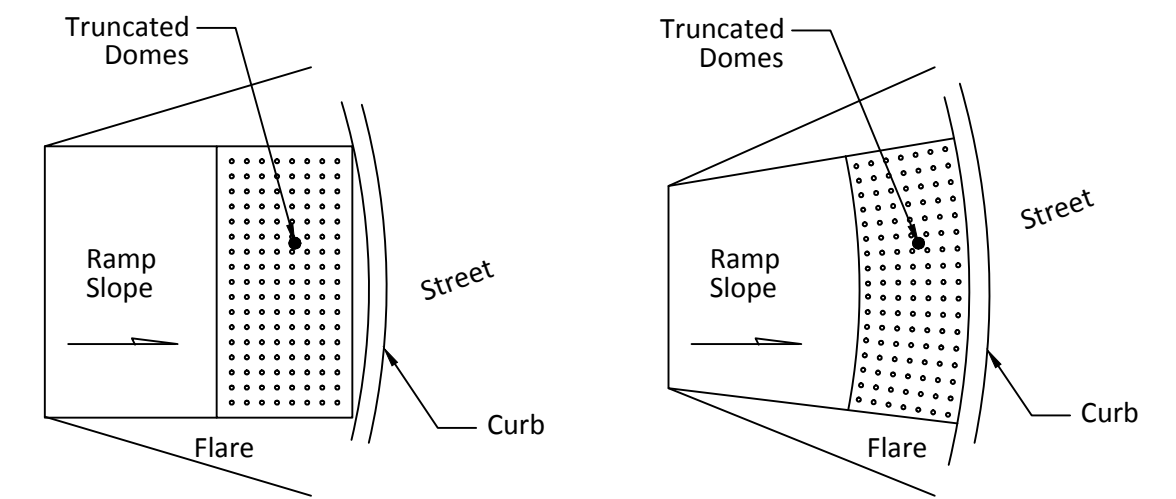

FILTREXX GREENLOXX NON-MSE LIVING WALL

Figure 1.2. Engineering Design for Filtrexx® GreenLoxx® Non-Mse Living Wall - Alternate Drawing

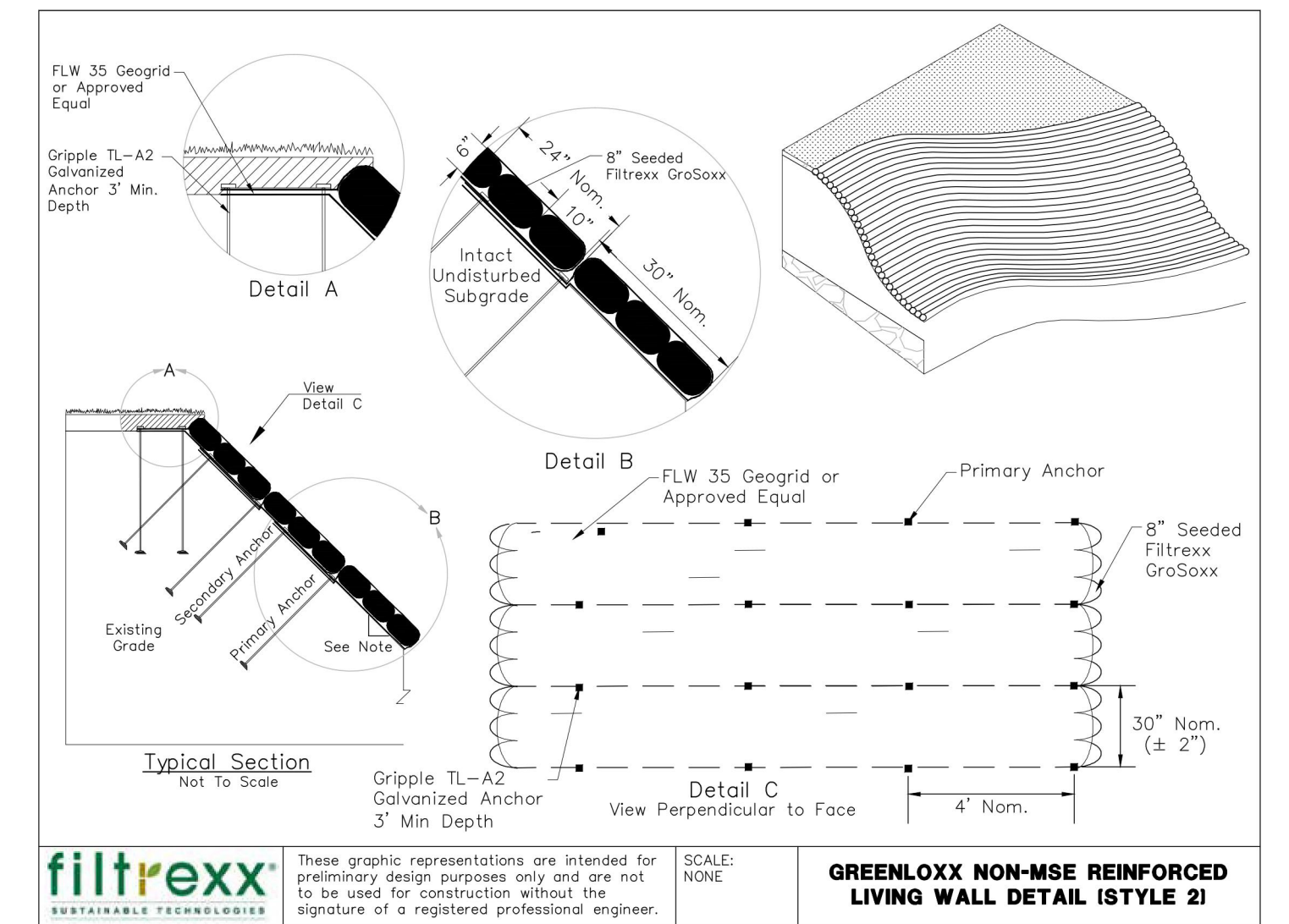

Table 7.10.2 Permanent Seeding

Seed Mix	Seeding Rate		Notes
	Lbs./acre	Lbs./1,000 Sq. Foot	
General Use			
Creeping Red Fescue	20-40	12-11	For close mowing & for waterways with <2.0 ft/sec velocity
Domestic Ryegrass	10-20	14-12	
Kentucky Bluegrass	20-40	12-11	
Tall Fescue	40-50	1-1 1/4	
Turf-type (dwarf) Fescue	90	2 1/4	
Steep Banks or Cut Slopes			
Tall Fescue	40-50	1-1 1/4	
Crown Vetch	10-20	14-12	Do not seed later than August
Tall Fescue	20-30	12-34	
Flax Pella	20-25	12-34	Do not seed later than August
Tall Fescue	20-30	12-34	
Road Ditches and Swales			
Tall Fescue	40-50	1-114	
Turf-type (Dwarf) Fescue	90	2 1/4	
Kentucky Bluegrass	5	0.1	
Lawns			
Kentucky Bluegrass	100-120	2	
Perennial Ryegrass	100-120	2	
Kentucky Bluegrass	100-120	2	For shaded areas
Creeping Red Fescue		1-1/2	

Note: Other approved seed species may be substituted.

MARSHALL AVE.
CONCRETE IMPROVEMENTS
GENERAL NOTES & DETAILS

CONTRACTORS
DESIGN ENGINEERING
CONSULTING ENGINEERS & SURVEYORS
NORWALK, OHIO

DATE: JANUARY, 2021 BY: ABE PROJECT NO.
DR: BLH REV'D BY: 19-350

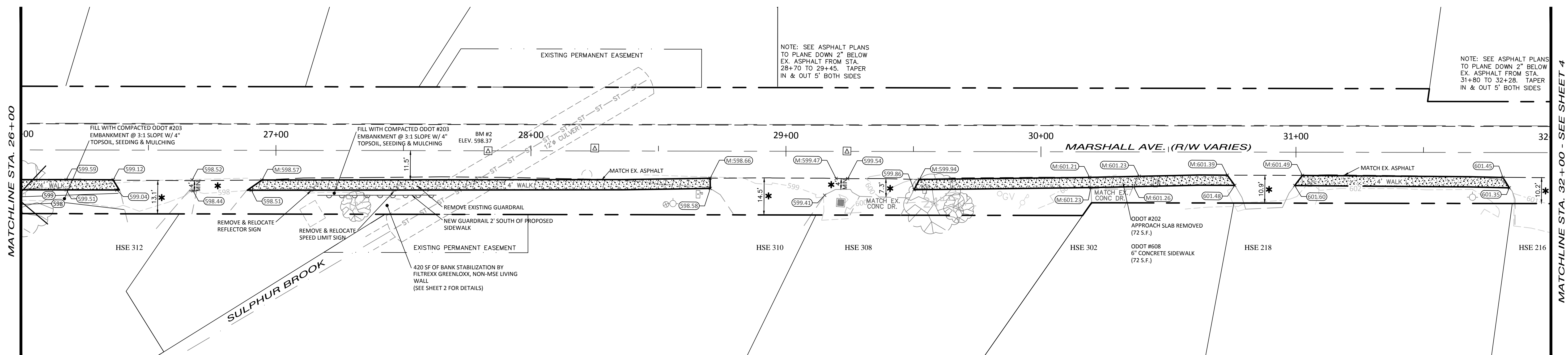
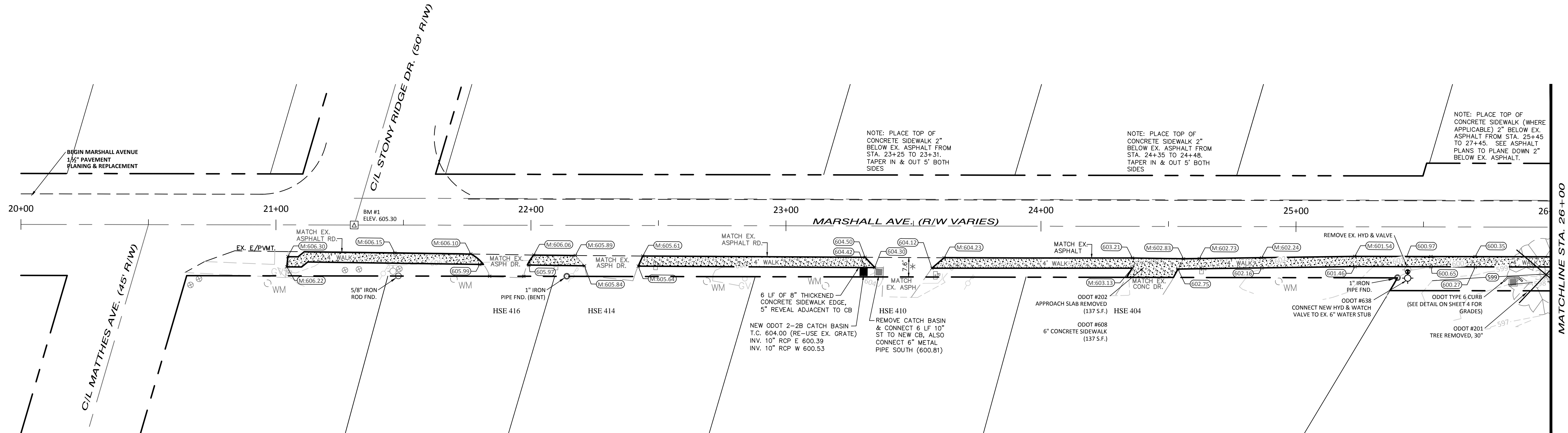

NOTES:

1. SIDEWALK CROSS SLOPE SHALL NOT EXCEED 2% AND 5% LONGITUDINALLY TO MEET ADA REQUIREMENTS.
 2. CONTRACTOR TO REMOVE & RELOCATE MAILBOXES AS NECESSARY.
 3. R/W CHANGES TO 50' WIDTH BETWEEN STA. 5+45± TO 9+55±.
 4. TOPSOIL, SEEDING & MULCHING REQUIRED FOR ALL DISTURBED LAWN AREAS AT BACK OF SIDEWALK.
- * NOT IN CONTRACT, SEE ASPHALT PLANS TO REPAVE DRIVE TO OBTAIN A 2% CROSS SLOPE FOR THE 4' WIDTH ADJACENT TO THE EDGE OF ROADWAY TO MEET ADA REQUIREMENTS, TAPER DRIVEWAY TO MEET EX. ASPHALT AT THE R/W LINE

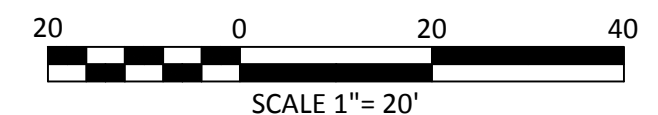

MARSHALL AVE.
CONCRETE IMPROVEMENTS

MARSHALL AVE. - STA. 0+00 TO 12+00

3	
4	

CONTRACTORS
DESIGN ENGINEERING
CONSULTING ENGINEERS & SURVEYORS
NORWALK, OHIO

DATE: JANUARY, 2021	EX'D. BY: ABE	PROJECT NO.
DR: BLH	REV'D BY:	19-350

File Name: \\ADSERVER\Drawings\19-350-Marshall Ave. Sidewalk - Perkins Township\19-350-Revised Jan. 2021.dwg

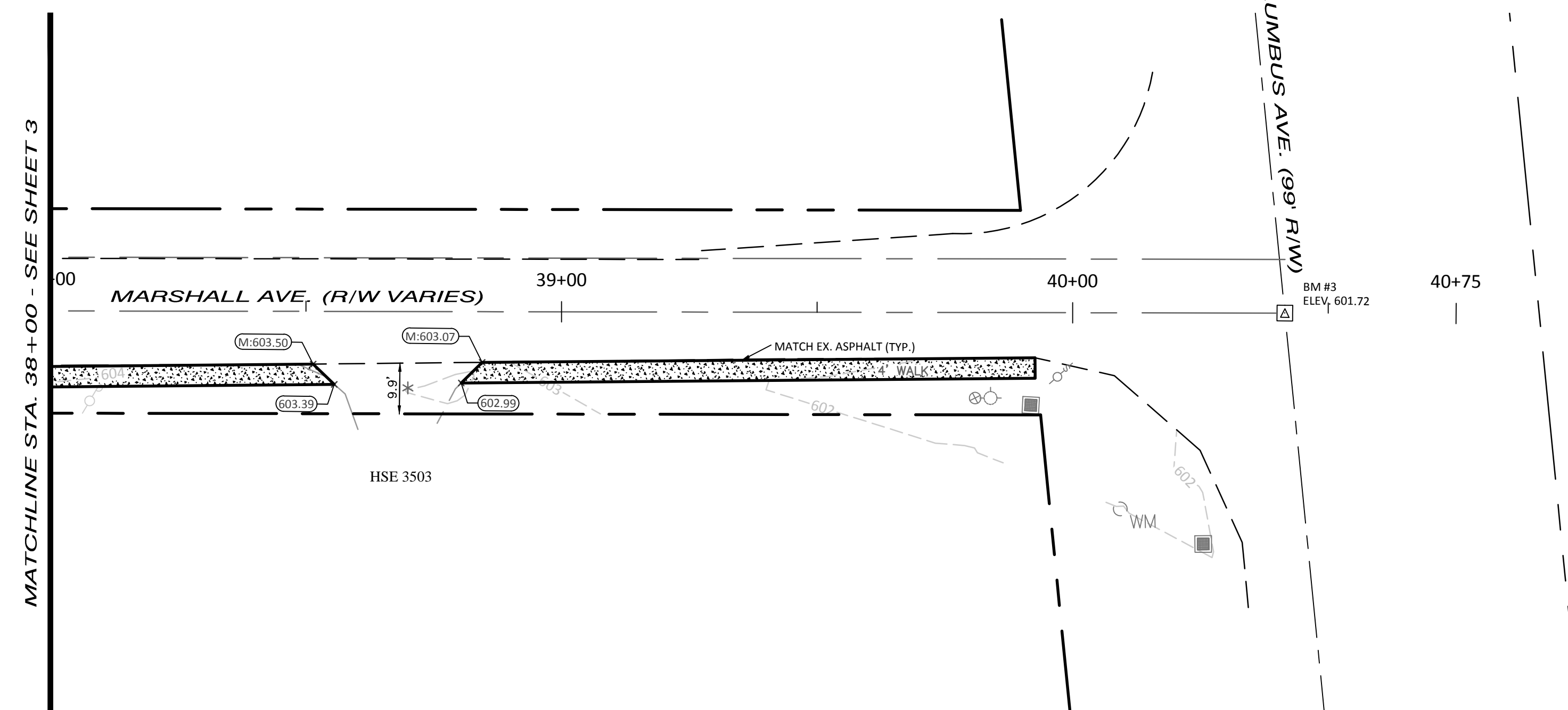
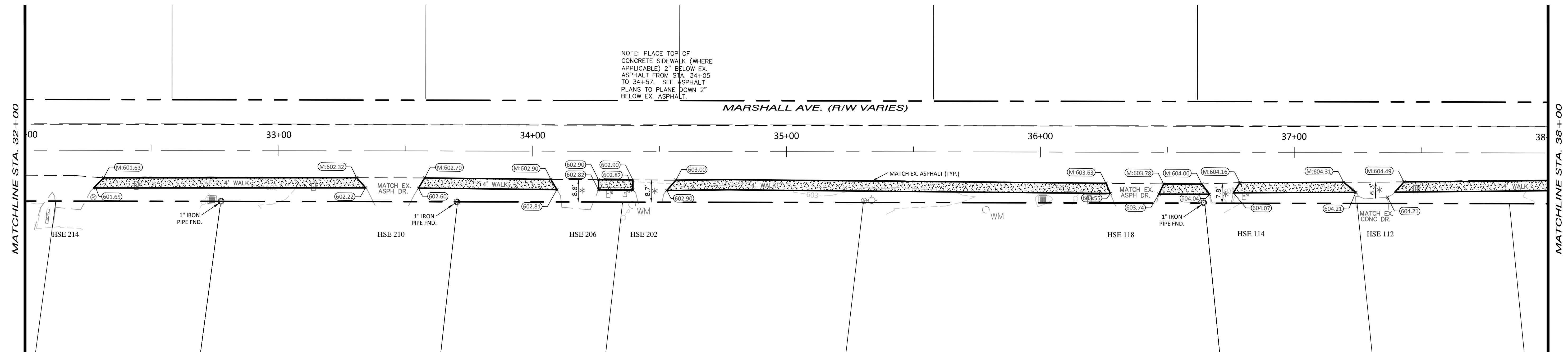

NOTES:

1. SIDEWALK CROSS SLOPE SHALL NOT EXCEED 2% AND 5% LONGITUDINALLY TO MEET ADA REQUIREMENTS.
2. CONTRACTOR TO REMOVE & RELOCATE MAILBOXES AS NECESSARY.
3. R/W CHANGES TO 50' WIDTH BETWEEN STA. 5+45± TO 9+55±
4. TOPSOIL, SEEDING & MULCHING REQUIRED FOR ALL DISTURBED LAWN AREAS AT BACK OF SIDEWALK.

* NOT IN CONTRACT, SEE ASPHALT PLANS TO REPAVE DRIVE TO OBTAIN A 2% CROSS SLOPE FOR THE 4' WIDTH ADJACENT TO THE EDGE OF ROADWAY TO MEET ADA REQUIREMENTS, TAPER DRIVEWAY TO MEET EX. ASPHALT AT THE R/W LINE

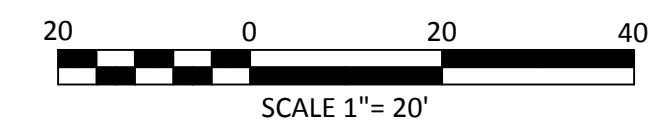
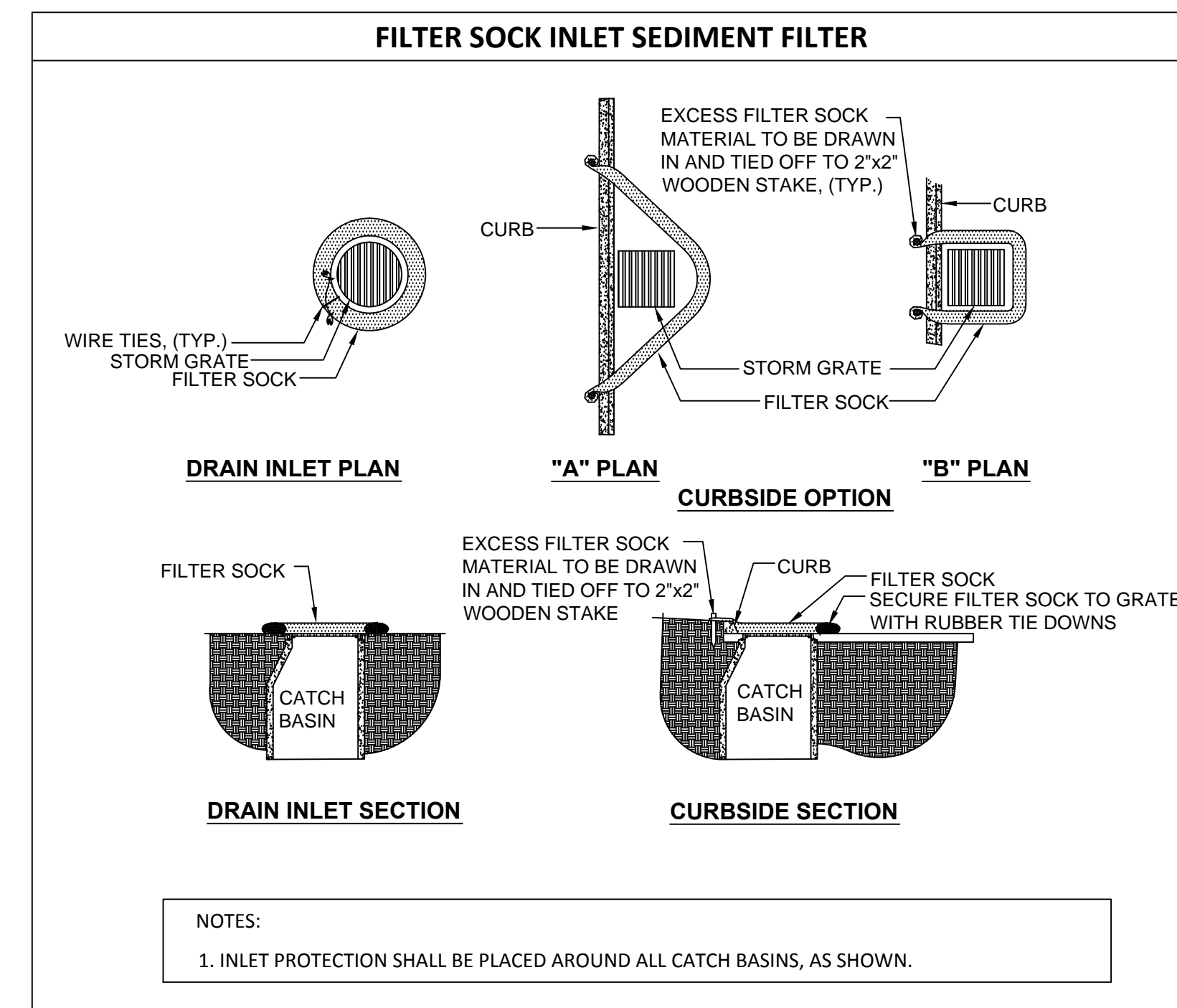
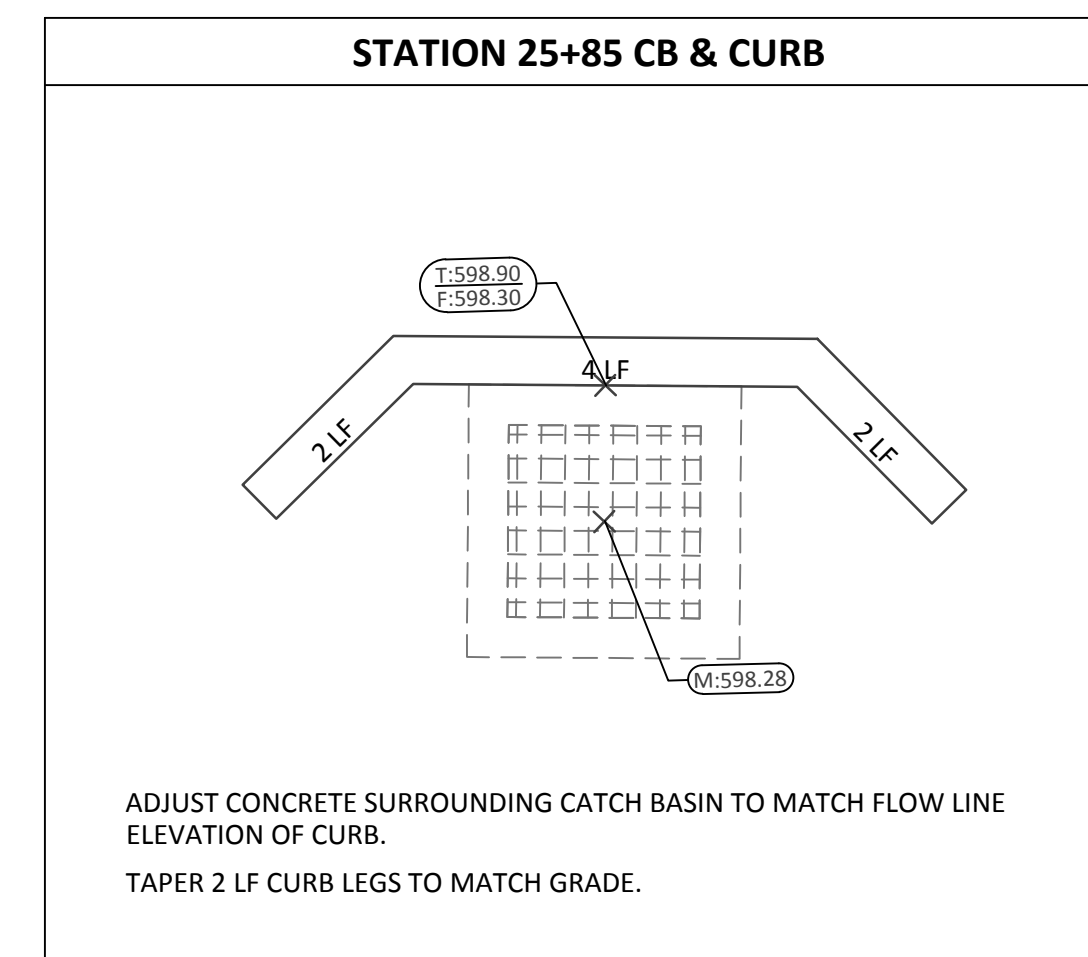

MARSHALL AVE.
CONCRETE IMPROVEMENTS

MARSHALL AVE. - STA. 12+00 TO 20+75

CONTRACTORS
DESIGN ENGINEERING
CONSULTING ENGINEERS & SURVEYORS
NORWALK, OHIO

DATE: JANUARY, 2021 BY: ABE PROJECT NO. 19-350
DR: BLH REV'D BY: